

**The brand by which all others are measured.**

**050/051/650/651 Series**  
Resilient Seated Butterfly Valves

**INSTALLATION, OPERATION  
& MAINTENANCE MANUAL**

## TABLE OF CONTENTS

### **Introduction**

Product Description	3
Design Features	3
Flange and Pipe Compatibility	3
Gasket Considerations	4
Operating Pressures	4
Product Identification	4

### **Installation Guidelines**

Ratings	4
Valve Seats	5
Installation Positioning	5
Valve Location and Orientation	5
Valve and Flange Preparation	6
Tool Requirements	7
Bolting Requirements	7
Handling and Storage	7

### **Valve Installation Procedure**

Pre-Installation Checklist	7
Initial Valve Positioning	8
Valve Alignment and Flanging	9
Bolt Tightening Sequence	10
Flange Bolting Requirements	11

### **Maintenance Instructions**

Basic Maintenance	12
Safety Precautions	12

# INTRODUCTION

## Product Description

The Delta T Products Series 050/051 and 650/651 resilient seated butterfly valves are designed for use in ASME Class 150 piping systems and are available in wafer and lug configurations. The standard size ranges for these series is as follows:

Series	Wafer	Lug	Class
050/051	1-1/2" thru 24"	2" thru 24"	125/150
650/651	2" thru 24"	2" thru 24"	125/150

Additional sizes thru 48" are available in Series 050/051, as well as double flanged versions. Please call factory for details.

## Design Features

The durability and reliability of the specially designed Delta-T cartridge seat has proven its reliability time and time again. The uniqueness of the rigid seat ensures positive valve sealing while maintaining low and consistent operating torque. The cartridge style seat incorporates various elastomers carefully bonded to a phenolic or aluminum stabilizing ring, guaranteeing no elastomer flow or movement, and virtually eliminating seat tearing or degradation due to bunching. In addition, the cartridge style seat reduces seat swell, which is very common in booted seat designs. The triple bushing design completely isolates the valve shaft from the valve body, allowing precise control of the valve disc and stem, and ensuring the lowest possible operating torque, and significantly increased valve service life.

## Flange and Pipe Compatibility

The Delta T 050/051 and 650/651 Series butterfly valves are designed to fit between standard piping flanges, as follows:

- ASME 125 Cast Iron Flanges (all sizes)
- ASME 150 Steel Flanges, Schedule 40 (all sizes)
- ASME 150 Steel Flanges, Schedule 80 (2" thru 10")
- ASME 300 Steel Flanges, Schedule 40

It is important to mention that when using Schedule 80 lined pipe or plastic pipe, special care must be used to ensure that the valve is centered between the flanges to prevent damage to the edge of the valve disc when moving from the full open to the full closed position\*. If there is any question about compatibility, check the disc chord ("Q") dimensions of the valve against the pipe ID dimensions.

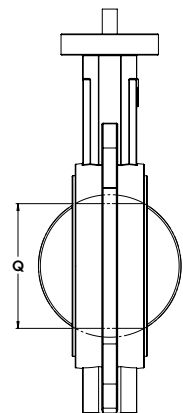

Size (in)	1.5	2	2.5	3	4	5	6	8	10	12	14	16	18	20	24
Q (in)	0.8	1.1	1.8	2.5	3.5	4.6	5.7	7.8	9.8	11.7	13.9	15.7	17.6	19.6	23.4

 **NOTE:** \*For plastic flanges, be careful not to overtighten the flange bolts which may cause warping and prevent proper sealing.

### Gasket Considerations

The cartridge seat design of the Delta T 050/051 and 650/651 Series butterfly valves are such that the elastomer seat extends beyond the valve face and provides a tight seal between the valve and the mating surface (pipe flange face). Gaskets are not required, and should NOT be used when the valve is installed between standard slip-on and weldneck type flanges.

### Operating Pressures

All Delta T Series resilient seated butterfly valves are rated to 200 psi bubble tight shut-off for sizes 2" through 12", and 150 psi bubble tight shut-off for sizes 14" and larger. Ductile iron lug style valves are capable for 200 psi uni-directional dead-end service through 12" per the directional arrow as indicated on the valve body, and up to 100 psi dead-end bi-directional service.

 **NOTE:** All PTFE seated butterfly valves are only rated to 150 psi bubble tight shut off for sizes 2" through 12".

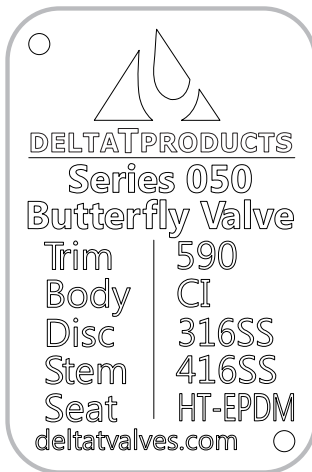

Figure 1

### Product Identification

All Delta T Series resilient seated butterfly valves have an identification tag attached to the valve body. Please see Figure 1, showing an example of the typical information provided for reference:

## INSTALLATION GUIDELINES

### Ratings

All Delta T Series resilient seated butterfly valves are intended for use at the maximum pressure and temperature ratings or less, as referenced by the part number for the applicable elastomer and seat combination. Please pay special attention to the selection of the correct configuration in regards to operating pressure, operating temperature, and compatibility of a specific elastomer with the intended line media. In addition, proper installation is critical to ensure the valve performs according to its rated pressure and operating torques.

 **NOTE:** Special consideration for PTFE/EPDM seated valves must be taken into consideration during the installation process. The pressure rating for all PTFE seated valves is limited to 150 psi differential pressure.

## Valve Seats

Delta T Series resilient seated butterfly valves are designed for bi-directional service; therefore, installation is not dependent upon the orientation of the seat. However, if lug valves are to be used in dead-end service, care should be taken as noted in the section titled “operating pressures”.

## Installation Positioning

Before installation of any Delta T Series resilient seated butterfly valve, it is critical to ensure the ID of the pipe and the pipe flanges are large enough to allow the disc edge to operate into the opening position without interference. This is the main technical issue with the installation of these types of resilient seated butterfly valves. Special care must be taken, and it is highly suggested to consult with an experienced installation technician to eliminate difficulties. Flange and pipe schedule compatibility is shown on page 3 of this installation and operation manual.

In order to prevent damage to the disc and the seat during the installation process, the valve disc should be slightly open but not extending beyond the face of the elastomer seat. Positioning the disc in this way, which is also referred to as “just about closed”, will ensure that the seat interference and resultant torque increase from installation, will be minimized.

## Valve Location and Orientation

As a best practice, Delta T series resilient-seated butterfly valves should be installed at least six (6) pipe diameters away from other piping elements, which includes pumps, other valves, pipe reducers, tees, elbows, etc. This is to minimize irregular flow patterns and maintain uniform flow throughout the system. If this minimum distance is impractical, at a minimum ensure that the disc of the valve does not interfere with nearby equipment.

Note that resilient-seated butterfly valves are designed to operate between two (2) flanges. For applications that require the use of only one (1) flange, such as **dead-end service**, special care must be taken in regards to installation orientation depending on the intended operating pressure. Please reference the section titled “Operating Pressures” for more detail.

Generally, it is best to install the valves with the shaft in the horizontal orientation. In this position, the stem and disc weights are distributed such that no additional gravitational forces contribute to wear and tear, which maximizes valve life. A horizontal valve stem also has the advantage of keeping the disc out of the flow path for fluid levels below  $\frac{1}{2}$  of the pipe diameter, which is especially critical for highly viscous or sludge type media. For applications like this, the lower edge of the disc should open toward the downstream direction.

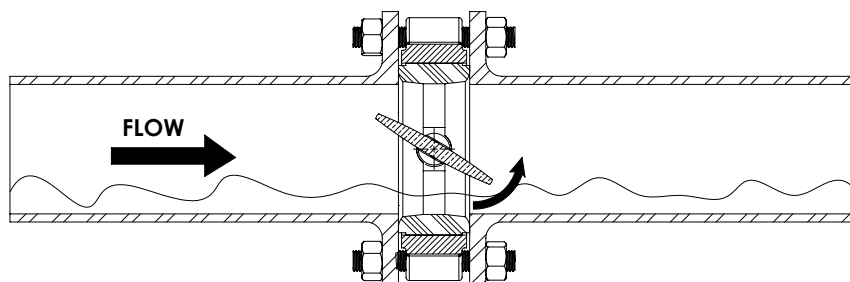

There are some applications where it may be more desirable to mount the valve vertically. **(Note: It is NOT recommended to mount the valve upside-down.)** In these instances, the vertical orientation is to help make the flow more uniform when the valve is placed downstream from some piping element, reducing noise, vibration, and wear to the piping system. This becomes more important as the valve gets closer to adjacent piping elements. The recommended shaft orientation after a given piping element is dependent on the orientation of that element.

After vertical elbows or tees, the downstream valve shaft should be vertical; for horizontal elbows or tees, the valve shaft should be horizontal.

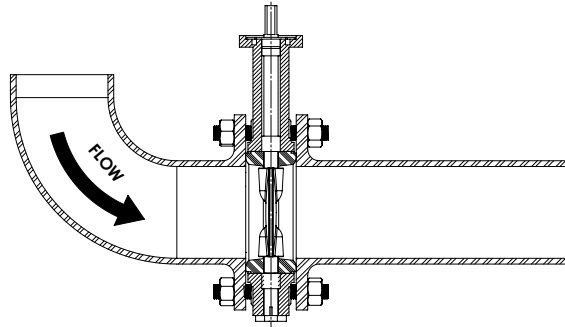

Valves downstream from an adjacent centrifugal pump should be oriented perpendicular to the shaft of the pump.

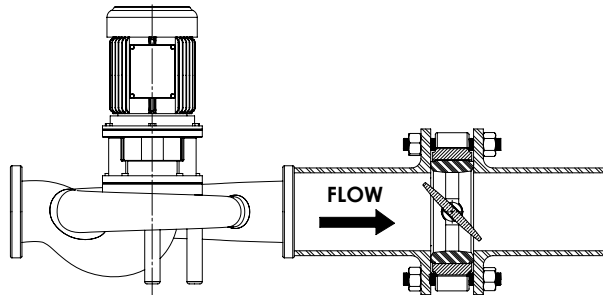

Adjacent valves used in combination should be installed at right angles to one another.

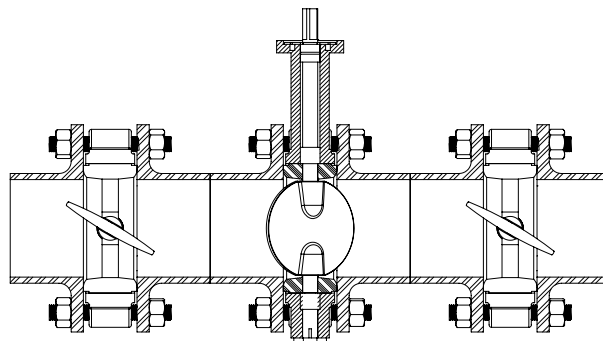

### **Valve and Flange Preparation**

It is essential that the valve and mating pipe are properly prepared for the installation process. Future problems can easily be avoided if best installation processes are followed. All valve seat and pipe flange faces should be free of dirt, grit, dents, scrapes, and other surface malformations which may interfere with the ability of the sealing surface to properly mate or adhere cleanly. The valve disc sealing surface should also be properly inspected to ensure no foreign debris will adversely affect the operation of the valve.



## **Tool Requirements**

Typically, the only tools required for installation are suitable wrenches for tightening the flange bolts and/or nuts required to secure the valve in service between the sealing surfaces. In some instances, a hoist may be required to secure placement of valves 10" and larger into service. Smaller valves can typically be installed by hand. Additional temporary pipe supports may be used to maintain the parallel alignment of flange faces.

## **Bolting Requirements**

The required bolting information is listed on page 11 (see Table 1), and is designed to provide information regarding size, type, and quantity of bolting recommended for installation of the Delta T Series resilient seated butterfly valves. All recommendations are in accordance with ASME 125/150 specifications. Please note flange bolting is not included with shipment of any valve.

## **Handling and Storage Suggestions**

It is recommended that the following steps be taken to ensure what we ordered was received in the intended manner:

- i) Check packing list to verify correct valve was received as ordered
- ii) Check for any damage during shipment
- iii) When moving the valve, take care to avoid damaging the flange face, disc sealing edge, and operators
- iv) If storage is required before installation, care should be taken to protect the valve from harsh environmental conditions
- v) Store the valve in such a manner to protect the disc sealing edge and the valve seat
- vi) Store the valve in a dry area with flanges protected in a suitable manner away from an unintended damage
- vii) If possible, keep the valve in a cool location, and away from direct sunlight

# **VALVE INSTALLATION PROCEDURE**

## **Pre-installation Checklist**

- 1. Remove any protective flange covers from the valve
- 2. Inspect the valve to ensure the flow path is free from dirt and debris
- 3. Be careful that the mating pipeline is also free from dirt and debris, such as rust, pipe scale, welding slag and debris, which can easily damage the seat and disc surfaces
- 4. Any operators, either manual or automated, should be installed PRIOR to installation, to ensure proper alignment of all connecting hardware, and also proper alignment of the disc and valve seat
- 5. Double check the valve identification tag to ensure that the valve materials meet the intended operating conditions. It is always critically important to double check all factors during the installation process
- 6. Check flange bolts or studs for proper size, threading, and length

**WARNING: PERSONAL INJURY OR PROPERTY DAMAGE MAY RESULT IF THE VALVE IS INSTALLED WHERE SERVICE CONDITIONS EXCEED VALVE RATINGS. PLEASE TAKE SPECIAL CARE TO DOUBLE CHECK ALL FACTORS DURING THE INSTALLATION PROCESS.**

## Initial Valve Positioning

Figure 2

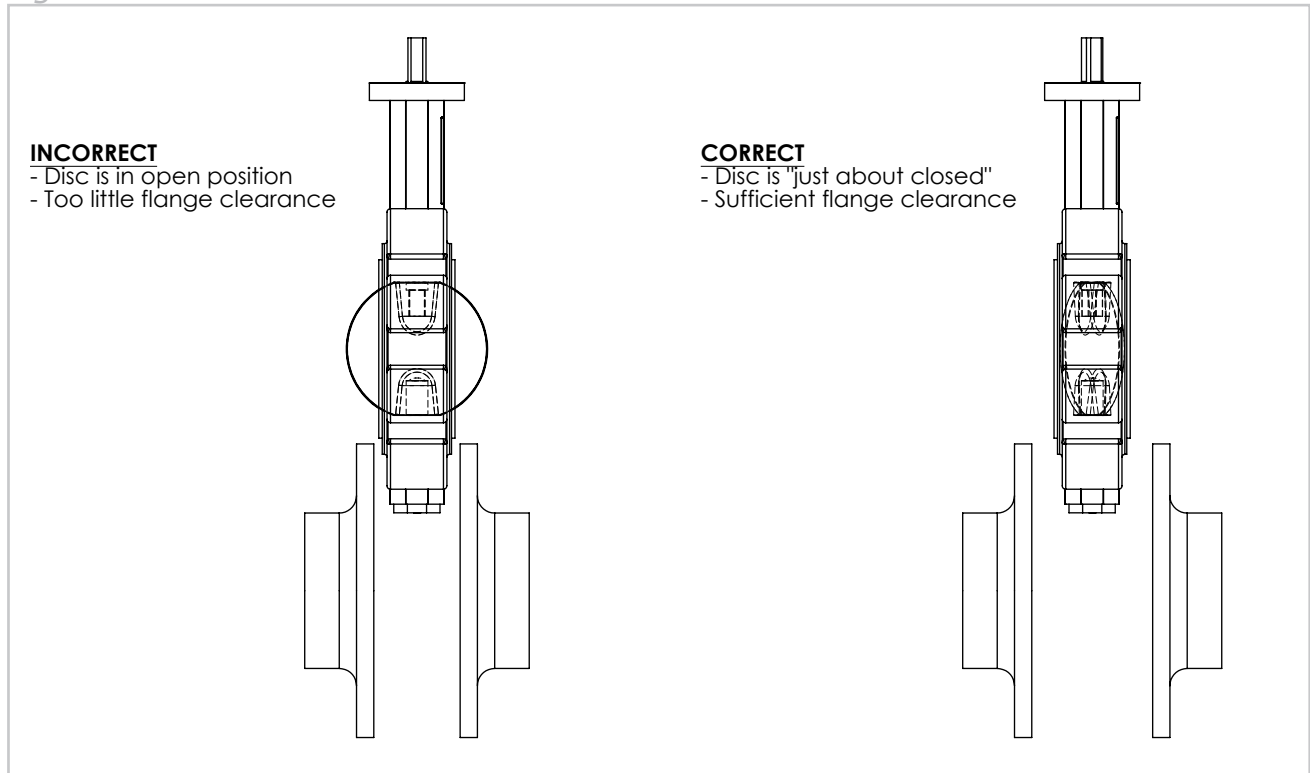

Before valve installation, it is important to properly align the mating pipe flanges. To install the valve, create enough space between the two flanges so that the valve body will fit without contact and carefully move the valve into position. Make sure the valve disc is in the "just about closed" position before insertion (See Figure 2 above).



**IMPORTANT NOTE:** Resilient seated butterfly valves are intended for use with schedule 40 raised face or flat faced flanged piping but may be used with alternative schedule piping if installed carefully. For schedule 10 and/or thin wall pipe or when using slip on flanges, extra care must be taken to align the seat on the flange face to avoid valve damage and ensure proper sealing. For heavy wall plastic pipe, the ID of the pipe should be checked for interference against the "Q" dimension of the butterfly valve.



## Valve Alignment and Flanging

Figure 3

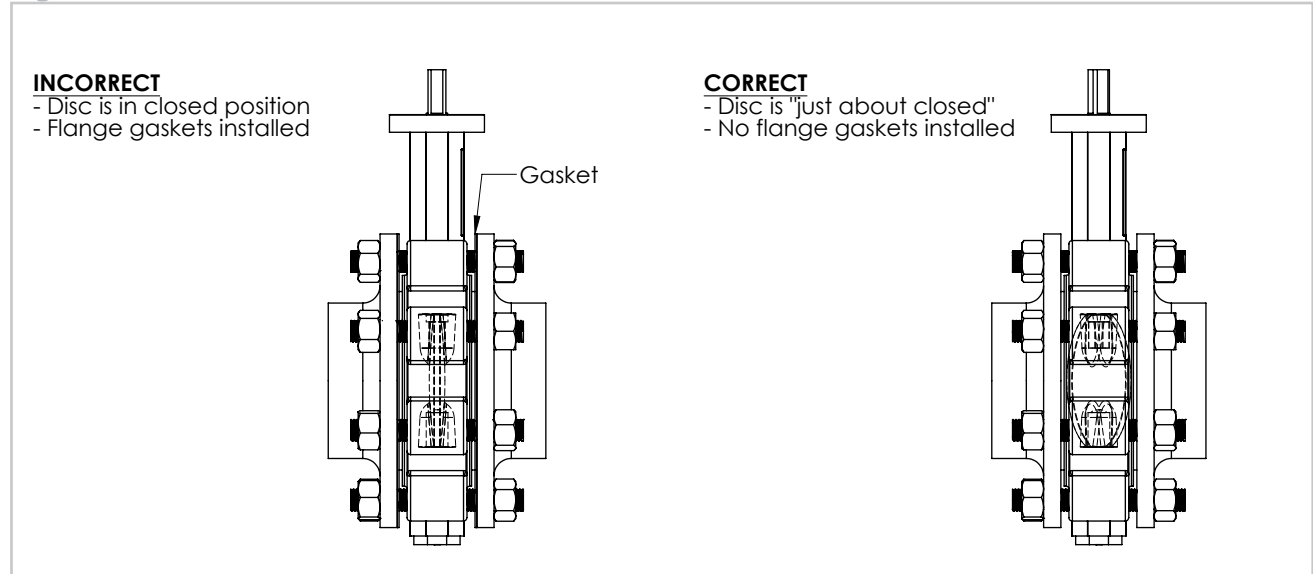

Do not install flange gaskets – the butterfly valve seat is designed to mate directly to the flange and provides the seal. Leave the disc in the “just about closed” position and center the disc with the pipeline (See Figure 3 above). The next step is to insert all necessary bolts to attach the valve to the flanges, which varies depending on wafer or lug style.

For wafer style valves, loosely install the four bolts that pass through the upper and lower body alignment holes as shown in Figure 4 below. Next, insert the remaining flange bolts until all bolts are in position, then hand tighten all bolts. For lug valves, loosely install all bolts between the flanges and the lugs and hand tighten when complete if using style C as shown below. If using lug style B, first insert threaded studs, then hand tighten the nuts on each side.

Figure 4

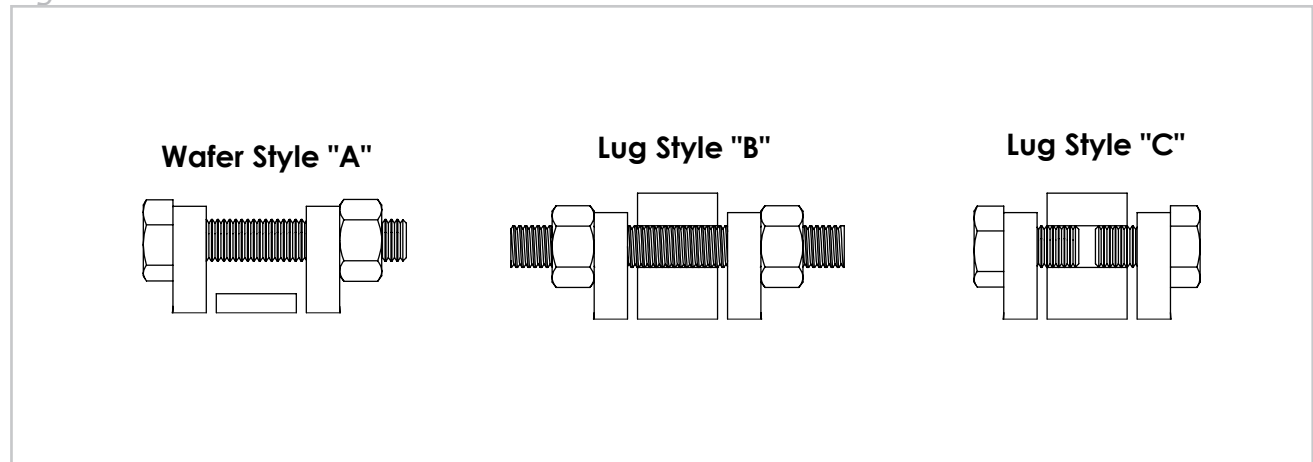
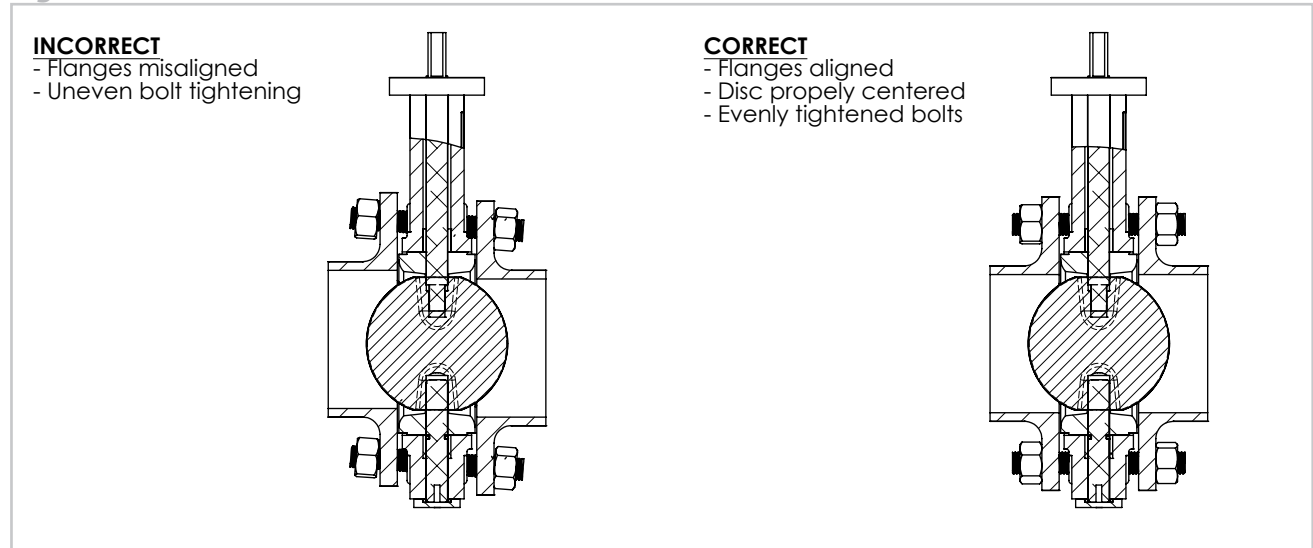

Figure 5



Before tightening the bolts, the valve needs to be positioned so that disc movement is free and unobstructed. Carefully open the disc to the fully open position and verify that there is no interference between the disc and the flanges. In addition, ensure that the flanges are properly aligned during tightening to minimize uneven stress or damage on the valve body or seat (See Figure 5 above). It is recommended to follow the Bolt Tightening Procedure below.

### Bolt Tightening Sequence

For lugged style valves (particularly important for PTFE seated valves), it is essential to tighten the flange bolting uniformly on both sides of the valve to assure that the cartridge seat is not forced out of position. Improper tightening can result in leakage through the stem seals. The proper tightening procedure is as follows (See Figure 6 on page 11):

1. If using a long stud and nuts as in style "B", after positioning the valve between the mating flanges, install the nuts in all positions to hand tight or just until they contact the flange face only. If using bolts as in style "C", tighten the bolts on both sides of the valve until they are hand tight or just contacting the flange face.
2. The nuts or bolts immediately on either side of the upper stem (position 1 & 2) should be tightened first. Start with position 1 and tighten bolts/nuts in  $\frac{1}{2}$  turn increments, alternating between the front and back flanges.
3. Once that position is tight, proceed to tighten the bolt/nut pair opposite from the pair that was just tightened and tighten in the same fashion (position 2).
4. Follow the same sequence as in steps 2 and 3 above on the opposite end of the valve near the lower stem (positions 3 & 4).
5. Tighten the remaining bolts (if any) in a star pattern around the valve and then re-check all bolts/nuts for tightness in a star pattern for all bolts/nuts (position 5, 6, 7, 8, etc). Make sure to alternate sides and tighten in  $\frac{1}{2}$  turn increments.

Figure 6

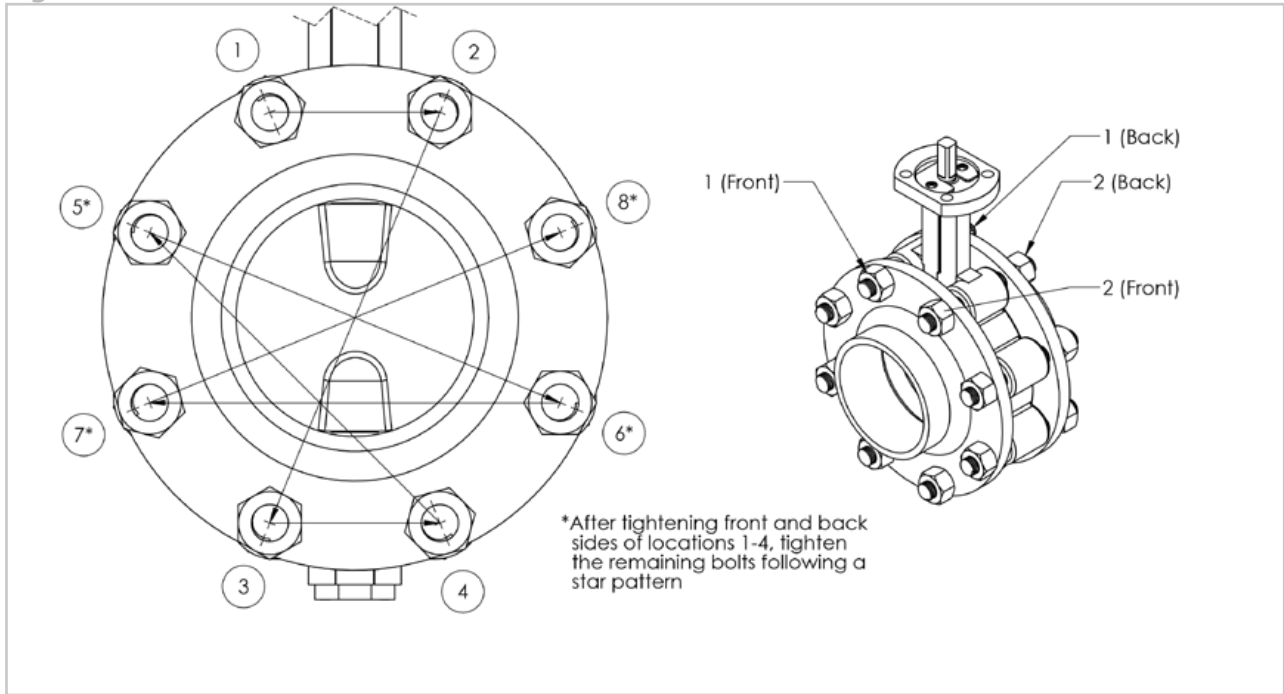

## Flange Bolting Requirements

Table 1

Valve Size	Diameter	Number		Bolt Length A	Stud Length B	Cap Screw Length C	Recommended Minimum Bolt Torque (ft-lbs)*
		Machine & Stud	Cap Screw				
2"	0.625	4	8	4.00	5.00	1.25	20-30
2.5"	0.625	4	8	4.25	5.25	1.50	20-30
3"	0.625	4	8	4.50	5.25	1.50	20-30
4"	0.625	8	16	5.00	6.00	1.75	20-30
5"	0.750	8	16	5.50	6.50	1.75	33-50
6"	0.750	8	16	5.50	6.75	2.00	33-50
8"	0.750	8	16	6.00	7.00	2.25	33-50
10"	0.875	12	24	6.75	8.00	2.25	53-75
12"	0.875	12	24	7.00	8.25	2.50	80-110

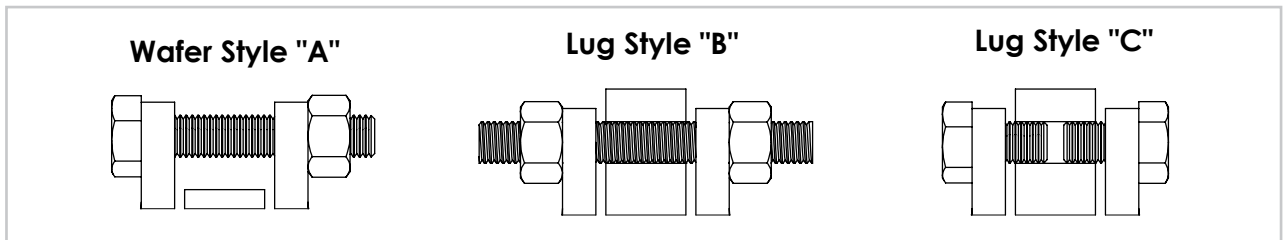

**\*NOTE:** These torque values are a general recommendation ONLY for minimum tightening torques. Many factors affect tightening requirements including bolt grade, pipe alignment, flange material and others. Field engineering personnel must make final torque value decisions. Call factory for flange bolting requirements up to 48" size.



## Maintenance

### Basic Maintenance

Delta T Series 050/051 and 650/651 resilient seated butterfly valves do not require regular maintenance unless the valve starts to leak. However, to lengthen the life of service, and to ensure safety, scheduled inspections are recommended. Here is a quick list of steps when performing an inspection:

- A) Visually inspect the body for any leaks and/or signs of wear and tear
- B) Operate the valve from full open to full closed to assure operability
- C) Check the valve for unusual sounds during operation
- D) Routinely check the tightness of flange bolting

### Safety Precautions

#### **IMPORTANT: BEFORE REMOVING VALVE OR LOOSENING FLANGE BOLTS**

- A) Verify that the pipeline is depressurized and adequately drained
- B) Identify flowing media and take any precautions necessary for toxic or flammable residual fluids
- C) Verify that the valve disc is closed before removing the valve
- D) Leave the operator (e.g. manual lever, actuator, etc.) attached when removing valve
- E) Do not detach the operator at any time while the line is pressurized